

# Home Security

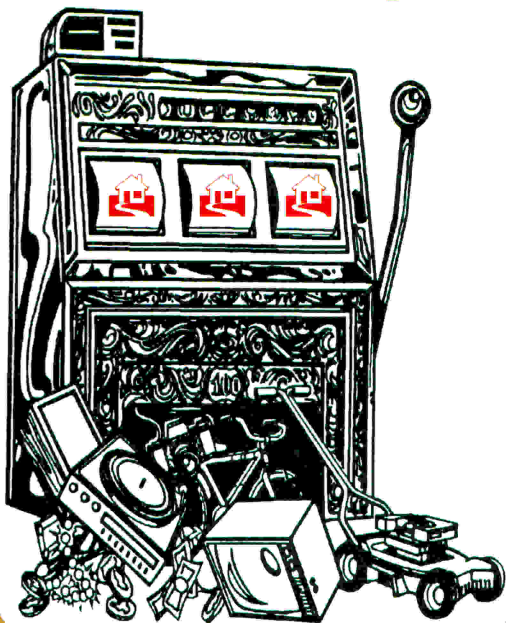

This pamphlet is produced by your  
Hillsborough County Sheriff's Office

# TABLE OF CONTENTS

	Page
<b>Outside Your Home . . . . .</b>	<b>2</b>
<b>Closing Your Doors to Burglary . . . . .</b>	<b>3</b>
<b>Hinge Doors . . . . .</b>	<b>4</b>
<b>Sliding Glass Doors . . . . .</b>	<b>6</b>
<b>Jalousie Doors . . . . .</b>	<b>7</b>
<b>Double Doors . . . . .</b>	<b>7</b>
<b>Garage Doors . . . . .</b>	<b>8</b>
<b>Outdoor Lighting . . . . .</b>	<b>8</b>
<b>Locking Out Trouble . . . . .</b>	<b>9</b>
<b>Rim Type/Surface Locks . . . . .</b>	<b>12</b>
<b>Securing Your Windows . . . . .</b>	<b>13</b>
<b>Double Hung Windows . . . . .</b>	<b>13</b>
<b>Awning Type Windows . . . . .</b>	<b>14</b>
<b>Sliding Glass Windows . . . . .</b>	<b>14</b>
<b>Casement Windows . . . . .</b>	<b>14</b>
<b>Jalousie Windows . . . . .</b>	<b>15</b>
<b>Security Film . . . . .</b>	<b>15</b>
<b>Padlocks and Hasps . . . . .</b>	<b>16</b>
<b>Operation Identification . . . . .</b>	<b>17</b>
<b>Home Security Checklist . . . . .</b>	<b>19</b>
<b>Notes . . . . .</b>	<b>20</b>

# Outside Your Home



The exterior of your home should not offer concealment to a burglar. A house with doors and windows in full view is a psychological deterrent. This forces an intruder to work in the open where he risks detection. Here's how you can discourage a burglar:

- Keep shrubs trimmed away from windows and doors so you don't provide a convenient hiding place for a burglar.
- Maintain adequate exterior lighting, especially on vulnerable access points to your home. (Some power companies offer a bright security lamp and post at a nominal monthly charge.)
- Don't leave ladders around the exterior of your house where they can be used by a burglar to gain entrance.
- Don't leave valuables such as lawn mowers, bicycles or tools in the yard or in an open or unlocked garage or shed. Your tools could be used to break into your home.
- Keep garage door closed and locked at all times. Many garage door openers are provided with a locking mechanism. The door leading from the garage to the house is a favorite access point for a burglar. Keep it locked also.
- Display house number conspicuously and have it well illuminated. This will aid the police, medical or other emergency vehicles in finding your home quickly if summoned. Urge your neighbors to do the same — you may be calling for them or vice versa.

*Never leave notes that can inform a burglar that your house is unoccupied.*

# Closing Your Doors To Burglary

## Hinge Doors

- The most common door type used in homes and apartments is the hinge door. It is important that all exterior doors be of solid wood core construction or steel clad. Avoid light gauge aluminum doors. Hollow core or composition board doors are not effective deterrents because they can be easily battered or bored. It is defeating the purpose of a good deadbolt lock to mount it on a hollow or foam core door.

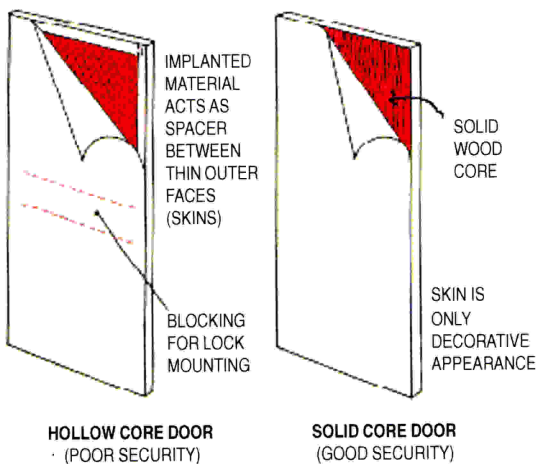

*Lock all doors even when gone momentarily — down the street, to the store, visiting the neighbors, etc.*

- If door hinges are exposed on the exterior of the door, nonremovable hinge pins should be used. To prevent removal of a door that has removable hinge pins, you can employ a headless screw or nail. Drill two holes opposite each other in the center of both leaves of the hinge. Insert headless screw or nail into the leaf on the door frame. Allow screw or nail to protrude  $\frac{1}{2}$  inch. When the door is closed, the screw will engage the other hinge leaf.

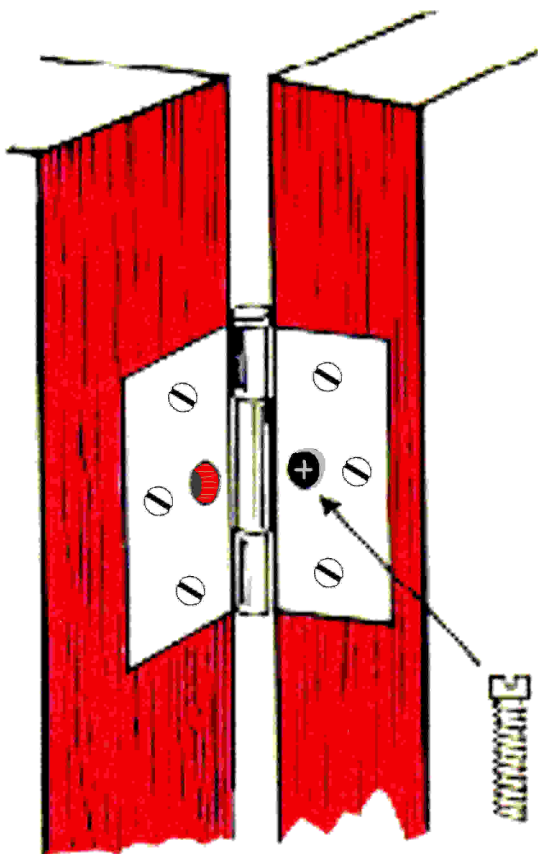

Drill a hole in the center of the hinge and insert a headless screw or nail in the door frame, allowing it to protrude approximately  $\frac{1}{2}$  inch.

- Inspect door frame and repair any splitting or rotting. Wooden frames should be at least 2 inches thick. If a hollow steel frame is used, the residual air space behind the frame should

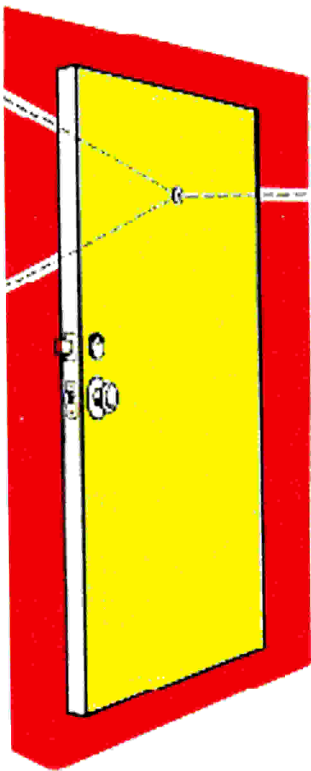

be filled with a crush-resistant material such as cement grout. This will prevent an intruder from wedging a crowbar between the door and frame to free up the door. You can strengthen the frame by removing some of the short screws in the door hinges and replacing them with longer screws (at least two inches). Also use longer screws in the lock strike plate.

- A solid wood door should have a wide angle viewer (180° minimum) installed in it for easy viewing of visitors without opening the door. It is inexpensive and easy to install. Do not rely on a chain latch. It is not a security device.

## Sliding Glass Doors

- Sliding glass doors are particularly easy targets for the burglar and are frequent points of entry. The locks they come equipped with can usually be quickly pried open. The doors can also be easily removed from their tracks unless they are properly secured.

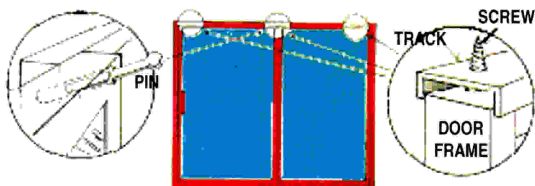

- To prevent removal of doors, install 1¼ inch pan head (large head) sheet metal screws in the upper track at both ends and in the middle so the door just clears the head of the screws. To secure a door in position, you can also drill a hole at a downward angle in the over-lapping frames of the door at the to center. Then insert an aluminum pin with a clasp which secures the pin in the door.

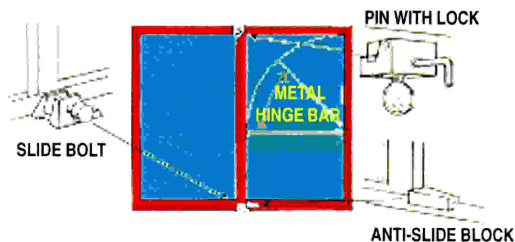

- There are different types of sliding glass door auxiliary locks that can be used, but key operated locks usually offer the best security, especially those using a deadbolt or pin mechanism.
- A metal bar that attaches to the side frame and fits across the middle of the sliding glass door, running parallel to the floor, can be used to prevent opening the door.

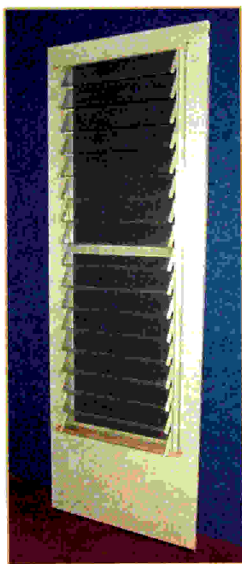

## Jalousie Doors

Jalousie doors are a poor security risk because a burglar can easily gain entry through them. The best solution is to replace them with solid wood doors. If this is not feasible, the door can be covered on the inside with heavy gauge expanded metal mesh or grillwork bolted to the door with carriage bolts.

## Double Doors

The inactive door can be adequately secured by installing cane bolts  $\frac{1}{2}$  inch in diameter x 12 inches long, on both top and bottom of door. The bolts should extend one inch into the upper door frame and one inch into the floor.

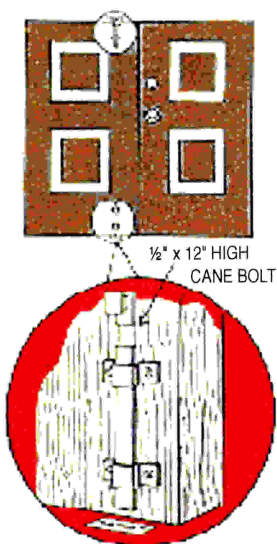

*Lock the front door when working in the back yard and vice versa.*



## Garage Doors

- A good, case hardened steel or titanium padlock, on which both ends of the shackle engage, should secure your garage door.  
*(See page 16 on Padlocks and Hasps for illustration.)*
- If the garage door rolls on tracks, a padlock can be locked to the track preventing the door from opening.
- Electronic garage door openers with automatic locking devices offer good security. Change the electronic combination on them periodically if they do not do so electronically.
- The door leading from the garage to the house should be a solid wood core door and should have a good quality deadbolt on it. This door is another favored access point for burglars because the garage offers concealment and access to your tools.

*Keep your garage door and any other doors leading from the garage to the house closed and locked whether you are home or not.*

## Outdoor Lighting

- Porches, entrances and yards should be well lit.
- Place some lights out of reach from the ground so bulbs can't be removed or broken.
- Aim floodlights away from your house so you can see if anyone is coming.
- Place lights at opposite corners to eliminate dark areas.
- Consider timers or motion detectors for outside lighting.
- New motion detectors have a chime which will ring inside your home when the motion detector turns on the lights on the exterior of your home, letting you know someone is outside.

## Locking Out Trouble

Sound locking devices cannot make a residence completely impregnable, but they can deter a burglar. They can force him into a situation in which he must break glass in order to enter — something he would probably like to avoid. The amount of money spent on security hardware should be proportional to what is being protected. But by the same token, purchasing security hardware which meets the minimum requirements listed below could also protect your family from bodily injury. Since prices for security hardware vary depending on the area, the manufacturer and differences in cosmetic features, the buyer should shop around.

- **Do not** use chain latches as a security measure. Chain latches can be ripped off the door with minimum pressure. The best way to check a person's identity is to use a wide angle viewer or doorscope.
- A common type of lock in many homes and apartments is the key-in-knob or spring latch type. This particular lock is easily defeated by the most amateur burglar with a credit card or screwdriver inserted between the latch and the strike plate. This lock offers no security and should be supplemented by a single or double cylinder deadbolt lock, a rim type, or a surface mounted lock. The dead latch is similar to the spring latch but has a small bar or plunger which will not permit opening with a shimming device. This is a poor security device since the plunger is very short and weak and should be supplemented by a quality deadbolt lock.

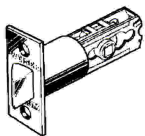

SPRING LATCH  
LOCK

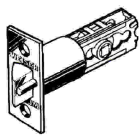

DEAD LATCH  
LOCK

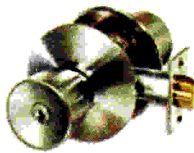

KEY-IN-KNOB

***(These locks do not offer adequate security)***

- A single cylinder deadbolt lock may be mounted on a solid wood core door when there is no breakable glass within 40 inches of the locking mechanism. The single cylinder deadbolt lock has a thumb turn piece on the inside.

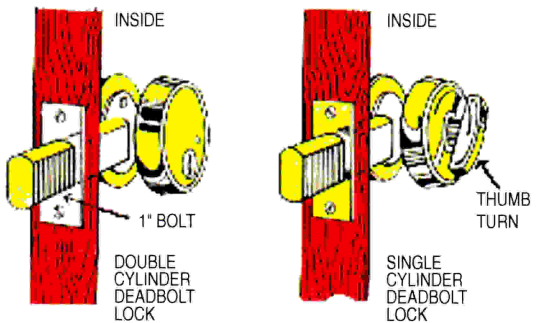

- A double cylinder deadbolt lock, which is keyed to operate from both the interior and exterior, should be used when there is glass within 40 inches of the interior locking mechanism.

**Caution:** The use of a double cylinder deadbolt lock can be a fire escape hazard. If this type of lock is used while the home is occupied, either leave the key in the lock or hanging near the lock. Children should be trained in the use of this lock and know the exact location of the key. When the dwelling is unattended, the key should be stored in a secure area.

- Both single and double cylinder deadbolts should meet these basic criteria to be a good security device.

*When moving into a new dwelling, have the tumblers in all the exterior locks changed. This can be done inexpensively by a licensed locksmith.*

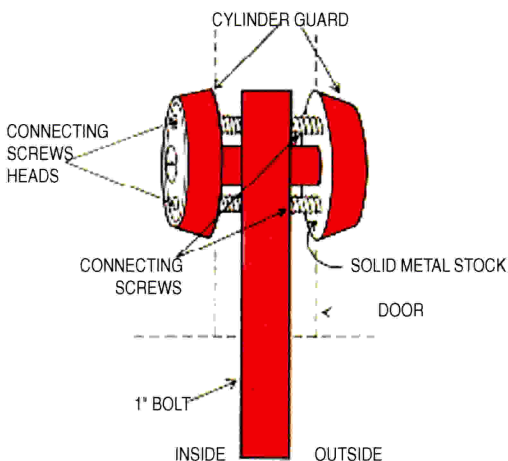

1. The bolt must extend a minimum of 1 inch and be case hardened steel or contain a hardened steel insert.
2. The cylinder guard must be tapered or spherical in design to make it difficult to grip with pliers or a wrench. It must be made of solid metal, not a hollow casting or stamped metal and preferably be able to turn freely.
3. The connecting screws that hold the lock together must both be on the inside. There must be no exposed screw heads on the exterior of the door.
4. The connecting screws must be at least  $\frac{1}{4}$  inch in diameter and screw into solid metal stock, not screw posts.

When shopping for a deadbolt lock, you may wish to take this diagram and description to a locksmith or hardware store to be sure the lock you buy meets all of the requirements.

*Do not allow children to open the door to strangers!*

## Rim Type/Surface Locks

- Rim type or surface locks use a vertical or horizontal deadbolt locking mechanism (see diagram). These locks are mounted on the interior surface of the door. A rim type lock is good security if it is the interlocking (jimmy resistant) type. With proper strike, an interlocking rim lock can be used on either in-swinging or out-swinging doors.
- Proper installation of this lock is extremely important. The strike should be secured to the door jam with minimum 2 inch wood screws. The lock must be bolted through the door with carriage bolts.

*Do not use wood screws to mount the lock.*

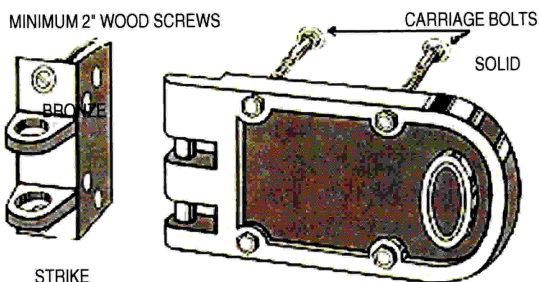

RIM TYPE OR SURFACE LOCK (JIMMY RESISTANT)

*As a second line of defense, you may want to consider a security closet for storage of valuables which are kept in the home. This closet should be equipped with a solid wood core door with hinges with nonremovable pins and also a good quality deadbolt lock.*

# Securing Your Windows

## Single/Double Hung Windows

The latches on many single or double hung windows can be easily jimmied or pried open. This type of window can be simply and inexpensively made secure.

- The window can be pinned by drilling a hole at a slight angle through the first sash and into, but not through the second sash. The window can then be pinned with a strong nail. Additional holes may be drilled for pinning the window in a slightly opened position for ventilation.

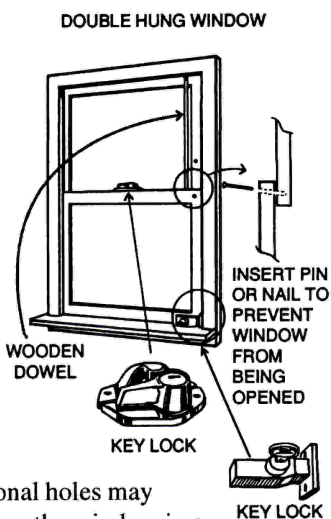

- Several types of keyed locks which offer effective protection are available for single or double hung windows. They are inexpensive and easy to install. But remember to master key all window locks for convenience and train children in their use. If keyed locks are used on your bedroom windows, discuss a fire escape plan with your family.
- The thumb turn lock in the center of most double hung windows offers very little security.
- A wooden dowel rod can be securely wedged between the top and bottom portions of the windows to secure the bottom sash. It can be secured to the inside of the window frame with pieces of hook and loop material. In this way, the rod can be shortened to allow for window ventilation. This will not secure the upper sash on double hung windows!

*Don't hide keys under a mat, over a door sill - or anywhere outside!!*

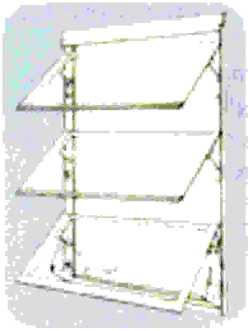

### **Awning Type Windows**

Awning type windows are difficult to secure. The removal of the inside operator handle adds some security, but keep the handle handy in case of an emergency. Awning windows should be tightly closed to enhance security.

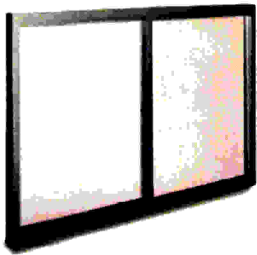

### **Sliding Glass Windows**

Sliding glass windows can be secured in the same manner as sliding glass doors. Pins through the frame, screws in the track or keyed locks can be used. Many inexpensive auxiliary locks are available.

The recommendations made for securing sliding glass doors on page 6 also apply to sliding glass windows.



### **Casement Windows**

Casement windows provide good security. Keyed locks are also available for this type of window for additional security. Make sure the latch works properly and the operator handle has no excess play.

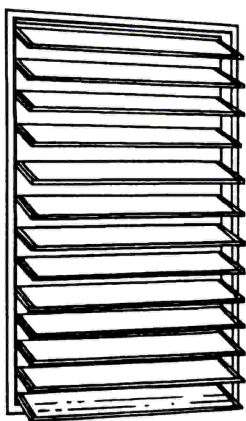

## Jalousie Windows

Jalousie windows are a very high security risk and should be replaced if at all possible. At comparable cost to installing additional security devices, the windows can be replaced with another type which offers better security.

For some awning, casement, and jalousie windows the use of decorative metal screens, bars, or grillwork may be the best solution for added protection. If used, especially in sleeping areas, mechanisms designed for inside quick release should be provided for emergency use.

## Security Film

Particular attention should be made to secure windows and any glass areas in or near your exterior doors. Security film will prevent the glass from shattering.

Security film will hold the glass together in a sliding glass door if an attempt is made to break it.

Security film can be used to deter “smash & grab” thieves in business areas.



## Padlocks And Hasps

### Padlocks

Padlocks should be of case hardened steel construction with a minimum 9/32 inch shackle. The lock should have a double locking mechanism on both the heel and toe of the shackle. It should be of heavy body construction with a minimum five pin tumbler.

#### MINIMUM 9/32 INCH SHACKLE



The bottom end of the padlock may have a key number stamped on it. This number should be obliterated and recorded elsewhere to eliminate the possibility of unauthorized key duplication.

**BODY**

**CASE HARDENED STEEL  
OR TITANIUM PADLOCK**

### Hasps

The hasp should be as strong as the lock and have no screws or bolts visible when secured. Screws which hold the hasp in place should be as long as the material holding them will allow. If installed on metal, carriage bolts with a large washer should be used to prevent prying of the hasp.

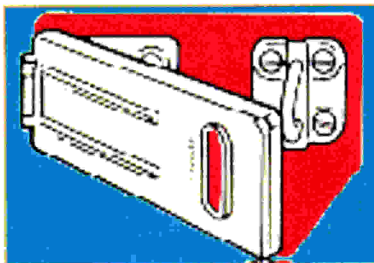

**HARDENED HASP**

## Operation Identification

- Operation Identification is the engraving of your valuables with your Florida Driver's License Number to deter burglars and also to prove ownership should the article be stolen and recovered by the police. Permanently marked valuables are more difficult for the burglar to dispose of and many times he won't bother stealing these items.
- Do not mark valuables with your Social Security Number. Federal regulations governing the identity of Social Security registrants make the numbers more difficult to trace.
- Electric engravers or diamond tip pens can be purchased inexpensively from a hardware store. You should mark your valuables ***FL*** followed by the 12-digit alpha-numeric code number on your driver's license. If you are not a driver, but you are at least 18 years of age, any Florida Driver's License Issuing Station will issue a Department of Motor Vehicles I.D. card. This I.D. card will have the same alpha-numeric code number for purposes of identification as a driver's license. This number can then be traced back to you in the event that marked stolen property is recovered by the police.



- Valuables that cannot be marked, such as antiques, silver, china, coins, etc. should be photographed in detail with a complete description of the article on the back of the photograph. These photographs should be kept in a safe place and used for identification purposes in the event of theft.

### OPERATION IDENTIFICATION RECORD

Valuable property should be marked with an electric engraver or any sharp etching tool with your Florida Drivers License number (FL DL \_\_\_\_\_). If you are not a driver, you can obtain an I.D. card and number from any Division of Drivers Licenses Issuing Station. Avoid marking on removable parts such as lids, doors, plates, etc.

Items which cannot be marked, antiques, china, coins, etc., should be photographed in color with the owner's identification. A complete description of the article should be written on the back of the photograph.

SUGGESTED ITEMS FOR MARKING: Bicycles, TV's, stereos, tape recorders, cameras, appliances, sporting goods, guns, typewriters, sewing machines, clocks and watches, power tools, lawn mowers, outboard motors, golf clubs, etc. Credit card numbers should also be recorded.

Property marked with your Drivers License Number FL DL \_\_\_\_\_

ARTICLE	MANUFACTURER AND MODEL	SERIAL NUMBER	LOCATION MARKED	PURCHASE PRICE

- After you have marked your valuable property, display an Operation Identification Sticker on all exterior doors or windows to advertise the fact. This may act as a deterrent to a potential burglar. Stickers are available from your local law enforcement agency.
- Make sure you have a record of all marked valuables and their serial number, make, model, and the location of your markings.

*Report suspicious persons or activities in your neighborhood to the police. Law Enforcement would rather check out 10 reports of a suspicious car or person than spend days and weeks following up on a burglary that could have been prevented!*

*Remember, a burglar doesn't look like a burglar.*

# Home Security Checklist

Yes No

- 1. Do exterior lights illuminate all entrances to your home?
- 2. Is shrubbery kept trimmed so a burglar can't hide near your windows and doors?
- 3. Are garage doors kept closed and locked at all times?
- 4. Are exterior doors made of solid core construction, including the door leading from garage to the house?
- 5. Is there a 180° peephole viewer on the front door?
- 6. Are sliding glass door secure with auxiliary locks or pinned, and are screws in the track to prevent removal of doors?
- 7. Are exterior doors secured with a deadbolt lock, (single or double cylinder) with a minimum 1 inch throw?
- 8. Are windows secured with auxiliary keyed locks or pinned with a nail?
- 9. Do you report suspicious persons or activity in the neighborhood to the police immediately?
- 10. Are doors locked at all times?
- 11. Are your valuables marked with your Florida Driver's License Number and do you have a record of them with complete serial number, make and model?

If you are able to answer YES to all of the above precautions, you have greatly decreased the likelihood of your home being burglarized.

*Do not open doors to strangers. Require identification from all repair and delivery personnel. If in doubt, check the authenticity of the identification by calling the company before letting the person into your home. Check I.D. through the peephole viewer.*

**FOR FURTHER INFORMATION  
CONTACT:**

**HILLSBOROUGH COUNTY  
SHERIFF'S OFFICE  
Crime Prevention Bureau  
2008 East 8th Avenue  
Tampa, Florida 33605  
Phone: 247-8115**

**Mail your inquiries to  
P.O. Box 3371  
Tampa, Florida 33601**

**FREE SECURITY SURVEYS  
FOR YOUR HOME, OFFICE  
OR BUSINESS**

**SECURITY SURVEYS:** Confidential surveys conducted for burglary, robbery, larceny and other types of loss.

**LECTURE PROGRAM:** Crime prevention lectures dealing with street crime and property crime can be arranged for your business, civic or social organizations.

**IMPORTANT NUMBERS**

- ① Sheriff's Emergency 911  
Ambulance - EMS  
County Fire**
  
- ② Crime Prevention Bureau 247-8115**
  
- ③ Sheriff Information 247-8000**

**OPERATION IDENTIFICATION RECORD**

Valuable property should be marked with an electric engraver or any sharp etching tool with your **Florida Driver's License** (FL DL: \_\_\_\_\_). If you are not a driver and are over 18 years of age, any Florida Driver License Issuing Station will issue a Department of Motor Vehicles I.D. Card. It cannot be stressed enough that you should not use your Social Security Number when engraving your items. Federal regulations governing the identity of Social Security restraints make the number next to impossible to trace!

Items which cannot be marked, such as antiques, chains, etc., should be photographed or video taped in color with the owner's identification. A complete description of the article should be written on the back of the photograph take.

**SUGGESTED ITEMS FOR MARKING:** Bicycles, TV's, stereos, cameras, video recorders, appliances, sporting goods, guns, computers, sewing machines, and many other expensive electric equipment. Credit card numbers should also be recorded.

*Property marked with your Drive'r License Number:* \_\_\_\_\_

ARTICLE	MANUFACTURE/ MODEL	SERIAL NUMBER(S)	LOCATION MARKED

Keep this list in a secure place.  
**DO NOT SEND A COPY OF THIS LIST TO SHERIFF'S OFFICE.**